

LAMB ELECTRIC

Model: 115330

DESCRIPTION

- Two stage
- 120 volts
- 7.2"/183 mm diameter
- Double ball bearings
- Single speed
- Peripheral bypass discharge
- Aluminum fan end bracket
- Aluminum commutator bracket

DESIGN APPLICATION

- Equipment operating in environments requiring separation of working air from motor ventilating air
- Designed to handle clean, dry, filtered air only

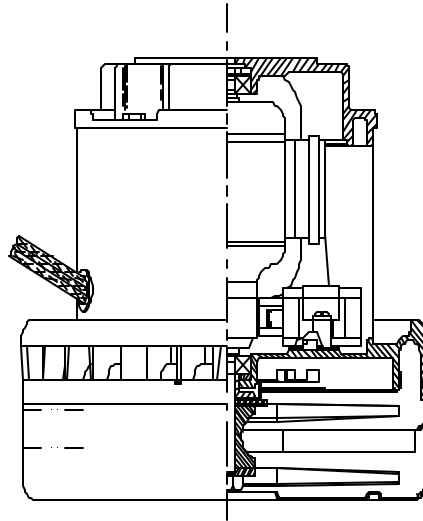

SPECIAL FEATURES

- Suitable for 120 volt AC operation, 50/60 Hz
- UL recognized, category PRGY2 (E47185)
- CSA certified, class 1611 01 (LR31393)
- Provision for grounding
- Tapered fan system
- The Lamb Electric vacuum motor line offers a wide range of performance levels to meet design needs

TYPICAL MOTOR PERFORMANCE.*

(At 120 volts, 60Hz, test data is corrected to standard conditions of 29.92 Hg, 68° F.)

ASTM DATA

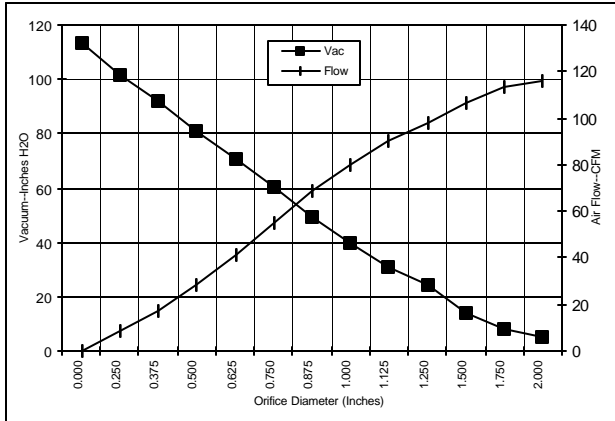

Orifice (Inches)	Amps	Watts (In)	RPM	Vac (In.H ₂ O)	Flow (CFM)	Air Watts
2.000	13.9	1512	16815	4.9	115.7	67
1.750	14.0	1520	16767	8.1	113.0	108
1.500	14.1	1526	16692	13.8	106.9	173
1.250	14.2	1543	16627	24.0	97.9	276
1.125	14.2	1541	16610	31.0	90.0	328
1.000	14.1	1531	16657	39.9	80.3	376
0.875	13.8	1502	16840	49.6	68.5	399
0.750	13.4	1457	17220	60.1	55.2	390
0.625	12.5	1363	17820	70.8	41.5	345
0.500	11.6	1267	18610	81.2	28.3	270
0.375	10.5	1156	19555	91.8	17.0	183
0.250	9.5	1055	20575	101.8	8.2	98
0.000	8.8	983	21422	113.4	0.0	0

METRIC DATA

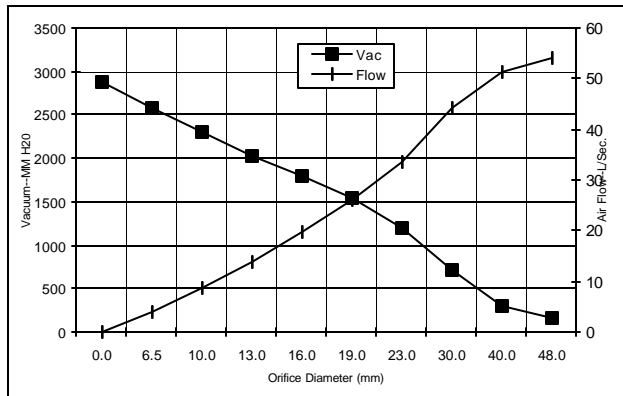

Orifice (mm)	Amps	Watts (In)	RPM	Vac (mm H ₂ O)	Flow (L/Sec)	Air Watts
48.0	13.9	1516	16794	161	54.0	85
40.0	14.0	1524	16715	307	51.3	154
30.0	14.2	1542	16618	707	44.2	305
23.0	13.9	1509	16794	1198	33.7	393
19.0	13.3	1455	17232	1532	25.9	389
16.0	12.5	1367	17796	1787	19.8	347
13.0	11.7	1277	18531	2036	14.0	278
10.0	10.7	1173	19413	2291	8.8	196
6.5	9.6	1060	20524	2573	4.1	102
0.0	8.8	983	21422	2880	0.0	0

Note: Metric performance data is calculated from the ASTM data above.

* Data represents performance of a typical motor sampled from a large production quantity. Individual motor data may vary due to normal manufacturing variat

Test Specs:	120 volts	Minimum Sealed Vacuum:	111.0"	ORIFICE:	7/8"	Minimum Vacuum:	46.0"	Maximum Watts:	1628
-------------	-----------	------------------------	--------	----------	------	-----------------	-------	----------------	------

DIMENSIONS

NOTES

1 LEADS POWER, #18 GA., ONE BLACK, ONE WHITE.
GROUND, #18 GA., GREEN WITH YELLOW STRIPE.

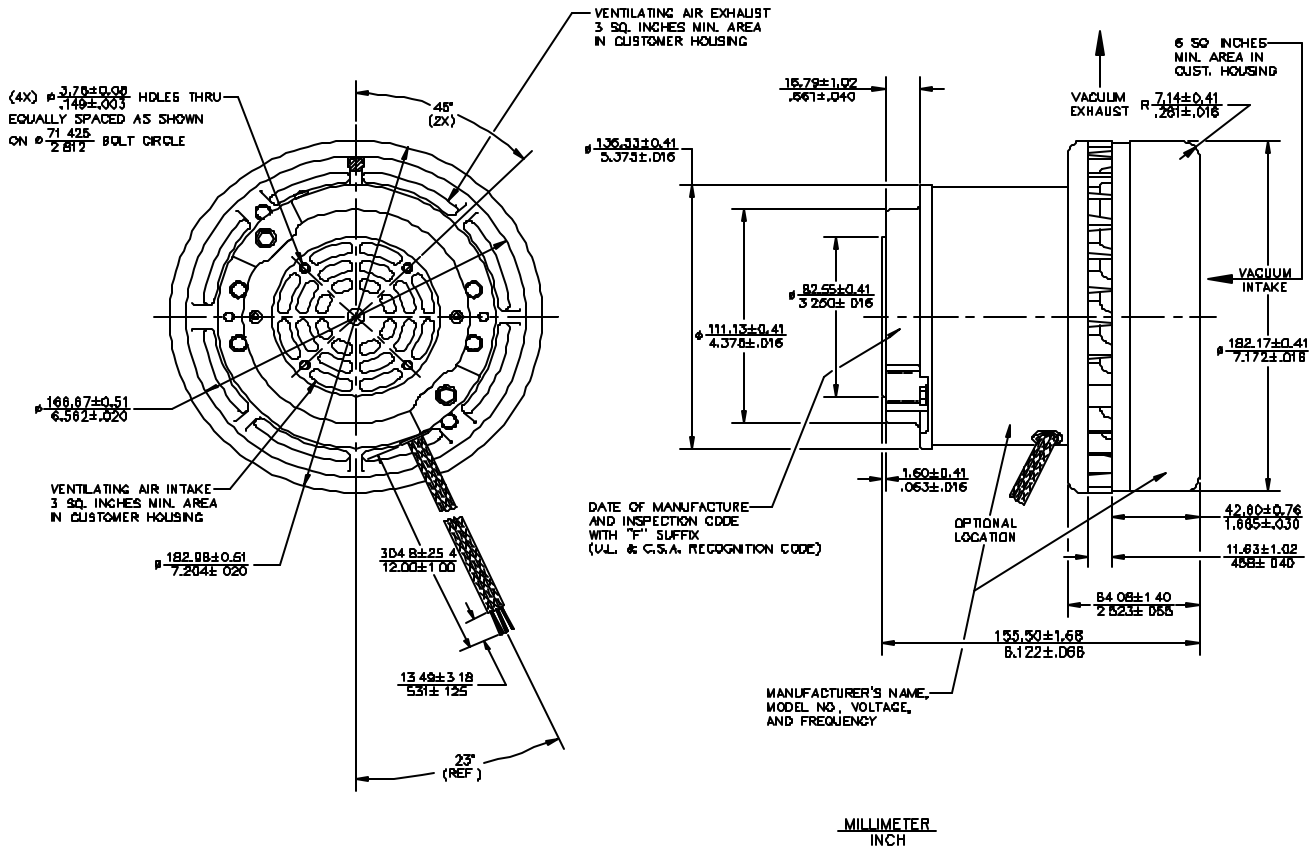

IMPORTANT NOTE: Pictorial and dimensional data are subject to change without notice. Contact factory for current revision levels.

WARNING - When using AMETEK Lamb Electric bypass motors in machines that come in contact with foam, liquid (including water), or other foreign substances, the machine must be designed and constructed to prevent those substances from reaching the fan system, motor housing, and electrical components. Lamb Electric vacuum motors other than hazardous duty models should not be applied in machines that come in contact with dry chemicals or other volatile materials. Failure to observe these precautions could cause flashing (depending on volatility) or electrical shock which could result in property damage and severe bodily injury, including death in extreme cases. All applications incorporating Lamb Electric motors should be submitted to appropriate organizations or agencies for testing specifically related to the safety of your equipment.

AMETEK/Lamb Electric Division
627 Lake Street
Kent, Ohio 44240
U.S.A.
Tel: (330) 673-3451
Fax: (330) 673-8994

Ametek GmbH
Weilimdorfer Str. 47
D-70825 Korntal-Munchingen
Germany
Phone: + 49-711-838-7876
Fax: + 49-711-838-7862

AMETEK/Singapore Private Limited
10 Ang Mo Kio Street 65
05-12 Techpoint
Singapore 2056
Tel: + 65-484-2388
Fax: + 65-481-6588