





REVIEW ALL STEPS BEFORE STARTING ASSEMBLY

HARDWARE LIST

		Quantity
<b>A</b>		1 7/8" Screw (26)
<b>B</b>		2 1/2" Screw (4)
<b>C</b>		Drill bit (if other than Phillips head)
<b>D</b>		Spacer block
<b>E</b>		Anchor stake kit

PRELIMINARIES

Selecting a Work Area

Select an area close to where the arbor will be installed. The assembly area should be relatively flat and open, at least 9'x7'. A lawn, driveway or wide path will be satisfactory. It is a good idea to lay out the arbor box on your work surface to protect the arbor from nicks and scratches. Two people are required for the assembly process. Always use caution when assembling or moving the arbor.

Optional Painting or Staining

If you wish to stain or paint your arbor, we recommend applying to individual components before assembly to ensure fullest coverage. Use a high quality exterior stain or paint. Be careful not to cover up guide marks on arches.

PARTS LIST

- 1** Header
- 2** Brace
- 3** Side Panel
- 4** Cap

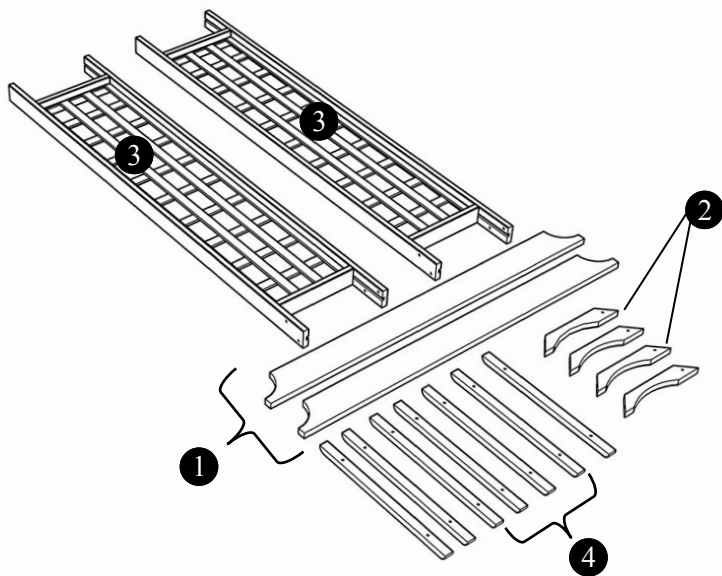

ASSEMBLED PRODUCT

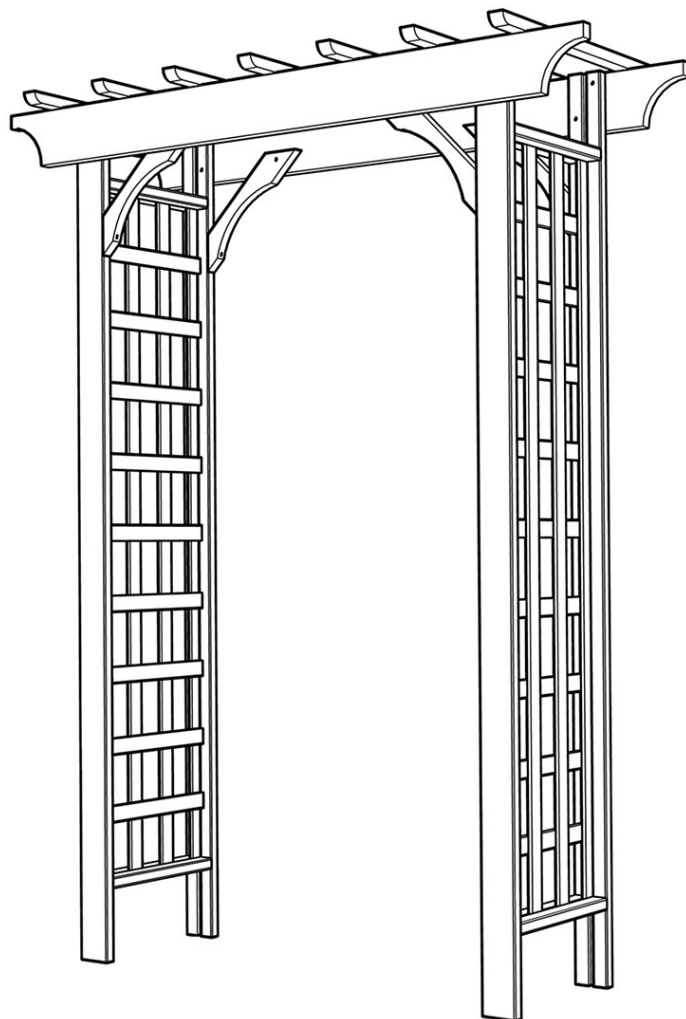

TOOLS REQUIRED

- Power screwdriver or drill
- Tape measure

Handy to have:

- Level
- Carpenter's square
- Stool or short ladder
- Bit holder may be needed if using a drill with a quick-change chuck

# ASSEMBLY INSTRUCTIONS

## PERGOLA ARBOR

### STEP 1

- Lay one of the 2" x 6" headers flat on your work surface, aligning a side panel to the pencil mark on the header. The side panel rail should be flush with the top of the header.
- Using one 1 7/8" screw, secure the side panel rail into the header. The second screw will be used when squaring up the arbor (see Step 2).
- Attach the second side panel to the opposite end of the header, aligning the panel to the pencil mark.
- Turn the assembly over and attach the second header following the same method as the first.

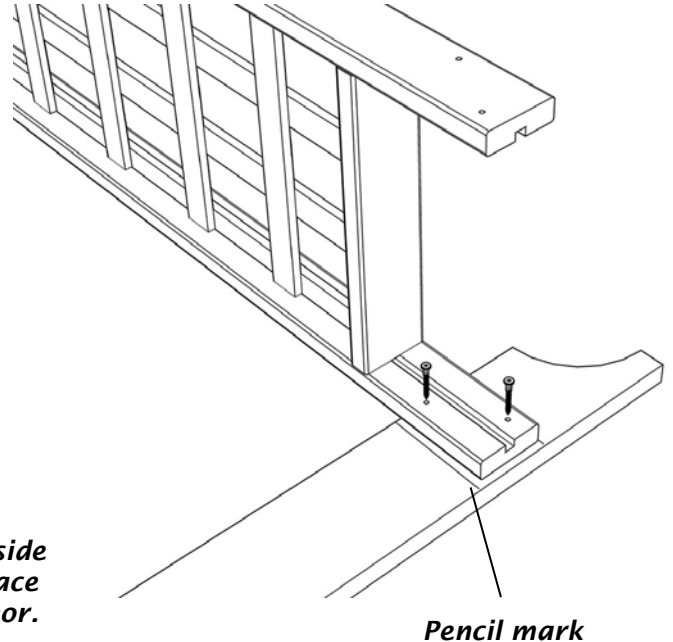

**NOTE:** Staples on the side panel lattice should face the outside of the arbor.

### STEP 2

- Now square up the arbor. This can be easily done with a large carpenter's square, a tape measure, or even a length of string, as shown below.

**With a square:**

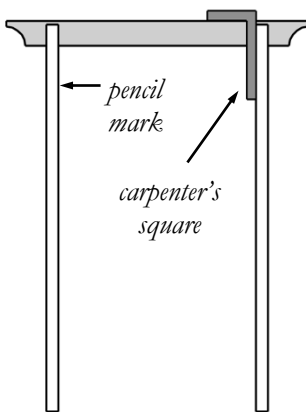

**With a tape measure or string:**

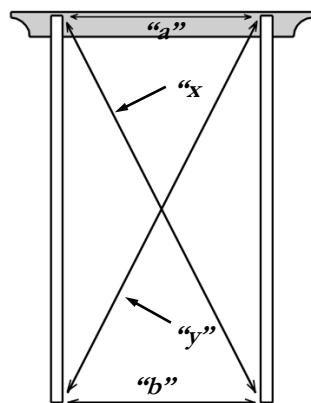

1. Measure the distance "a" at post tops.
2. Set bottom of posts to same spacing "b".
3. Measure diagonal distance "x".
4. Check opposite diagonal distance "y".  
When  $a=b$  and  $x=y$ , the arbor is square.

- When the arbor is squared up, drive the second screw at the top of each side panel post into the header.

## ASSEMBLY INSTRUCTIONS

# PERGOLA ARBOR

### STEP 3

- Attach all four braces to the side panels, each with one 2 1/2" screw. Align bottom edge of brace with pencil mark.
- Double-check your side panel posts to make sure they are square with the header board and parallel to the post on the other side.
- Using 1 7/8" screws, attach the braces to the headers.

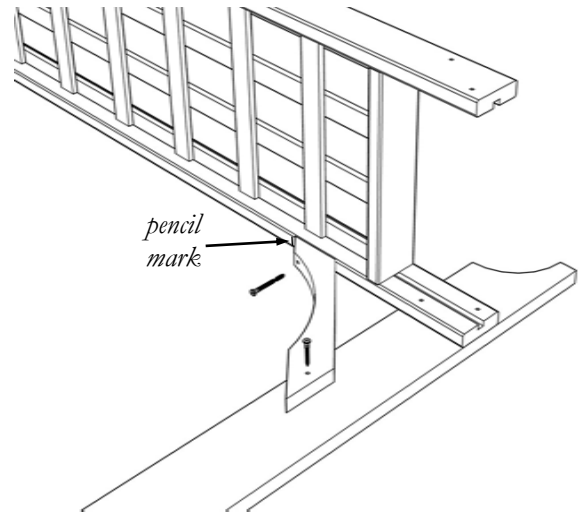

### STEP 4

- Center one of the cap pieces across the two headers, placing it between the two marks. Fasten with 1 7/8" screw through hole centered into top of one header. Secure cap to second header in same manner.
- Using spacer provided, attach other cap pieces at equal intervals, 3 caps on each side of the center one.
- Assembly is complete. Carefully raise arbor upright. Anchoring steps are on next page.

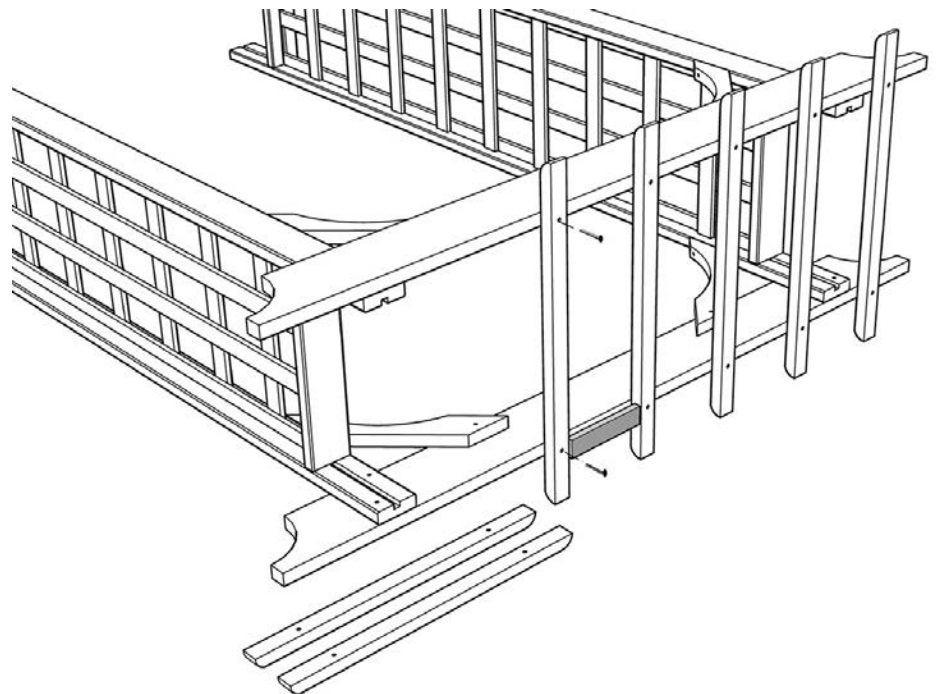

## ASSEMBLY INSTRUCTIONS

# PERGOLA ARBOR

### OPTIONAL — ANCHORING THE ARBOR

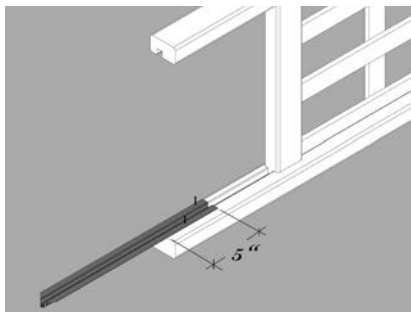

*This arbor may be secured using a variety of techniques. These include attaching to an existing structure or anchoring with gravel or river rock instead of concrete. The instructions below represent secure mounting with concrete. Use caution when moving the arbor to its final placement. Two people are required to lift or move the arbor.*

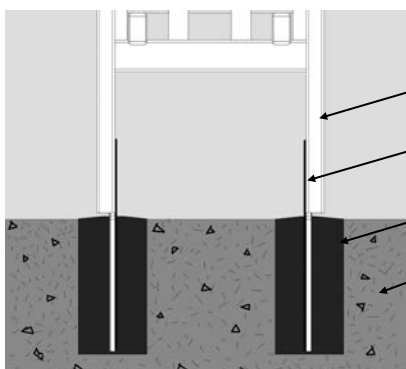

1. Attach all four anchors to the bottom of the arbor using the provided screws, two screws per anchor, staggering the screws.
2. Measure the distance in between all anchors and dig four 8" diameter holes to accommodate the anchors.
3. Carefully lift the arbor and position in place, avoid tilting the arbor on the anchors.
4. Plumb and level the arbor.
5. Mix concrete according to the manufacturer's instructions, fill each hole within 1/4" of the bottom of each post, posts should not be set in the concrete.

### ENVIRONMENT

Congratulations, this garden structure is crafted from natural and chemical-free Western Cedar. Wood, as a building component, is recognized by the USDA<sup>1</sup> as yielding fewer greenhouse gases than other common materials. The use of wood provides substantial environmental benefits when compared to oil-based plastics. Using natural, untreated wood in your garden is not only the beautiful choice, but it reduces the exposure of plants, people and animals to potentially harmful chemicals.

You can trust the LWO Corp. name for environmentally conscious, exceptional outdoor products.

<sup>1</sup>USDA.com Release No. 0426.11

### ABOUT YOUR PRODUCT

This garden structure is made from natural and untreated Western Cedar, a species that is known for its natural resistance to pests and decay. This product features furniture-style craftsmanship to ensure strength and durability over the years to come.

Like all wood products subjected to weather, small hairline cracks may develop. These should in no way impair the strength and usefulness of the furniture.

### CARE AND MAINTENANCE

If left unstained, your garden structure will silver within a year or two of exposure to the elements. Silvering is a natural occurrence and is often considered a desirable look. The overall integrity of your garden structure is not compromised during this process. The inherent rot and pest resistance of the wood will provide a degree of protection and help your garden structure to endure over the years.

If you wish to further protect your structure from the long-term effects of aging or to stabilize the color/finish of your product, we recommend applying a quality water or oil-based finish. Best results can be achieved by using Penofin ([www.penofin.com](http://www.penofin.com), 1.800.PENOFIN) as per manufacturer's instructions. If you desire to paint your product, we recommend a quality oil or acrylic primer coat prior to applying the final coat(s). Be sure to allow sufficient time for your product to dry.