Ambient Weather WS-14 Wireless 8-Channel Floating Pool and Spa Thermometer with Daily Min/Max Display User Manual



Table of Contents

1	Introduction.....	2
2	Getting Started	2
2.1	Parts List	2
2.2	Floating Pool and Spa Thermometer Sensor Set Up.....	2
2.3	Sensor Placement.....	9
3	Maintenance.....	10
4	Display Console Set Up	10
4.1	Display Console Layout	11
4.2	Sensor Operation Verification	11
5	Display Features.....	11
5.1	Console Operation.....	11
5.1.1	Set Mode	11
5.1.2	Viewing the High and Low Alarms	12
5.1.3	Alarm Defaults	12
5.1.4	Setting the Min and Max Alarm.....	12
5.2	Manually Reset Max/Min	13
5.3	Channel Selection	13
5.4	Sensor Search Mode.....	13
5.5	Best Practices for Wireless Communication	13
5.6	Adjustment or Calibration	13
5.6.1	Remote Sensor Temperature Calibration.....	14
5.6.2	Indoor Temperature Calibration	14
6	Glossary of Terms	15
7	Specifications.....	15
7.1	Wireless Specifications	15
7.2	Measurement Specifications	15
7.3	Power Consumption.....	15
8	Troubleshooting Guide.....	15
9	Accessories	17
10	Liability Disclaimer.....	17
11	FCC Statement.....	17
12	Warranty Information	18

1 Introduction

Thank you for your purchase of the Ambient Weather WS-14 Wireless 8-Channel Floating Pool and Spa Thermometer with Daily Min/Max Display. The following user guide provides step by step instructions for installation, operation and troubleshooting. To download the latest manual and additional troubleshooting tips, please visit the FAQ website:

<http://ambientweather.wikispaces.com/ws14>

2 Getting Started

 **Note:** The power up sequence must be performed in the order shown in this section (insert batteries in the remote transmitter(s) first, Display Console second).

The WS-14 weather station consists of a display console (receiver), and a thermometer (remote transmitter).

2.1 Parts List

QTY	Item
1	Thermometer transmitter (F007PF) for pool/spa Dimensions (LxHxW): 8.5" x 4.2" x 3.7" (216 x 106 x 95mm) LCD Dimensions (LxW): 1.1 x 0.62" (27 x 16mm) Remote sensor depth: 7.1" (180mm)
1	Display Console Frame Dimensions (LxHxW): 4.0 x 2.95 x 1.00 in LCD Dimensions (LxW): 1.96 x 1.77" LCD Segment Height: 0.78 inches
1	User Manual

2.2 Floating Pool and Spa Thermometer Sensor Set Up

 **Note:** We recommend fresh alkaline batteries for temperature ranges between -4 °F and 140 °F and fresh lithium batteries for temperature ranges between -40 °F and 140 °F. The solar panel does not charge the batteries, so rechargeable batteries are not needed or recommended.

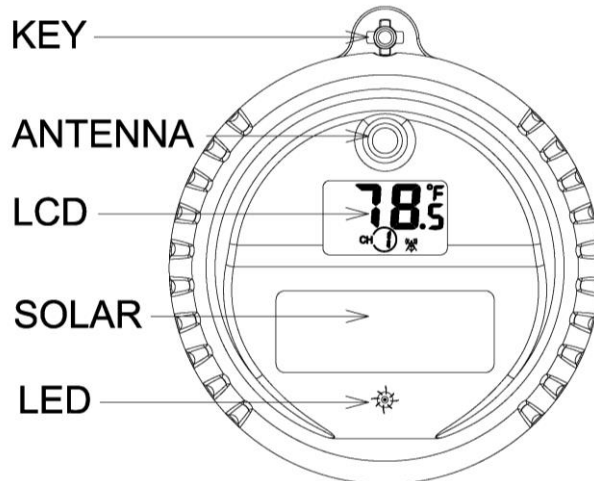

Figure 1

1. To insert the batteries,, (1) Twist the KEY lid to unlock, (2) remove the key, and (3) twist the main body of the sensor by removing the lid, as shown in Figure 2 .

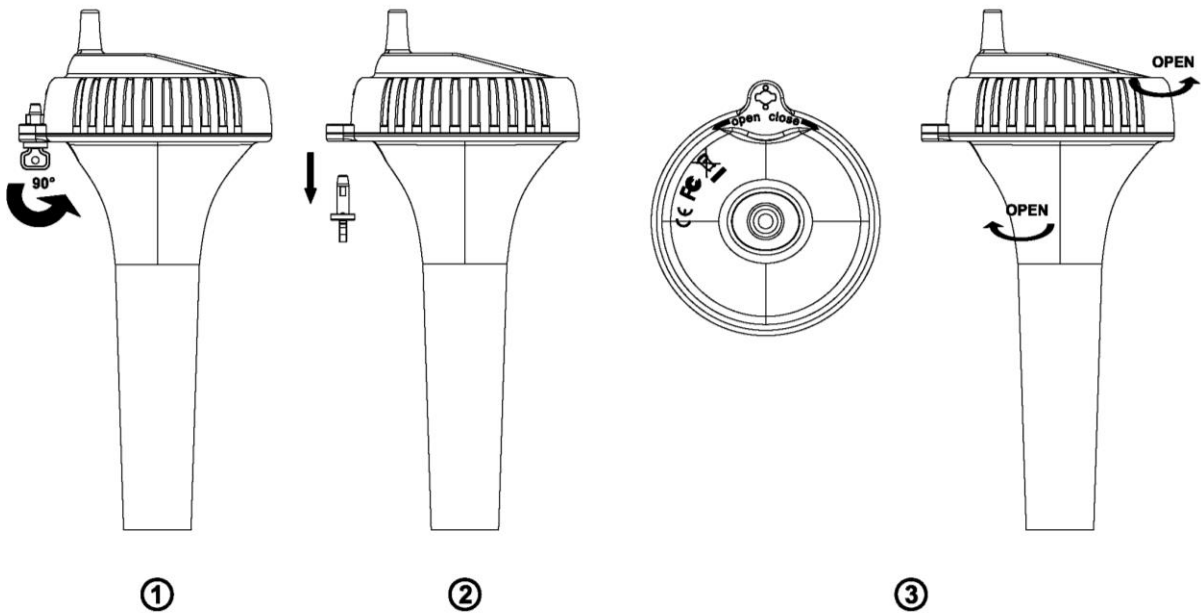

Figure 2

 **IMPORTANT NOTE:** Turn the lid counter clockwise to open, like the lid of a jar (Figure 3). Turning the lid clockwise may overtighten the lid.



Figure 3

2. The floating thermometer includes dip switches for assigning channel numbers. **BEFORE** inserting the batteries, locate the dip switches on the inside cover of the lid of the transmitter. Figure 5 displays all four switches in the OFF position (factory default setting).

NOTE: The second generation pool float includes a reset button.

If the display does not power up after inserting the batteries, press the reset button shown in Figure 4.

If your pool float does not include a reset button, cover the solar panel with one hand, remove the batteries, wait 60 seconds, reinsert the batteries, and uncover the solar panel.

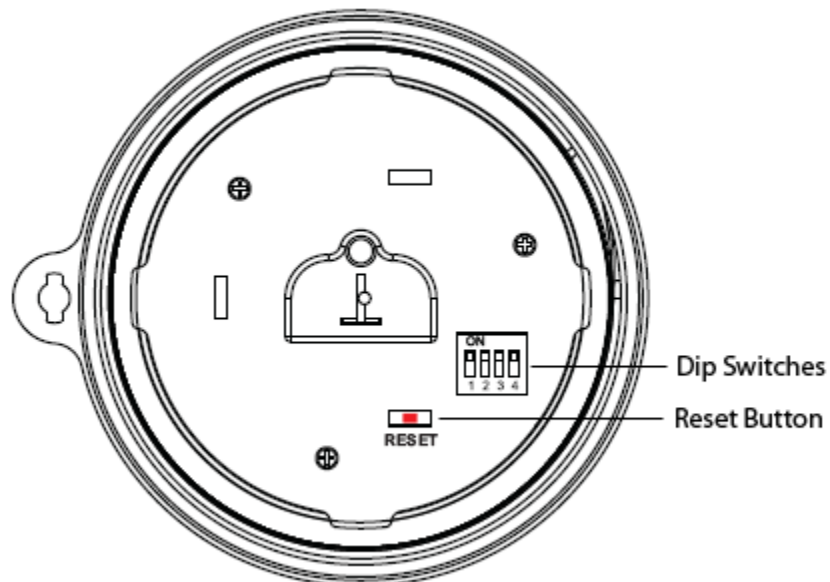

Figure 4



Figure 5

Channel Number: The WS-14 supports up to eight transmitters. To set each channel number (the default is Channel 1), change Dip Switches 1, 2 and 3, as referenced in Table 1.

Temperature Units of Measure: To change the transmitter display units of measure (°F vs. °C), change Dip Switch 4, as referenced in Table 1.

DIP SWITCH				FUNCTION
1	2	3	4	
DOWN	DOWN	DOWN	---	Channel 1
DOWN	DOWN	UP	---	Channel 2 (optional)
DOWN	UP	DOWN	---	Channel 3 (optional)
DOWN	UP	UP	---	Channel 4 (optional)
UP	DOWN	DOWN	---	Channel 5 (optional)
UP	DOWN	UP	---	Channel 6 (optional)
UP	UP	DOWN	---	Channel 7 (optional)
UP	UP	UP	---	Channel 8 (optional)
---	---	---	DOWN	°F
---	---	---	UP	°C

Table 1

3. Reference Figure 6. Install 4 x AAA batteries.

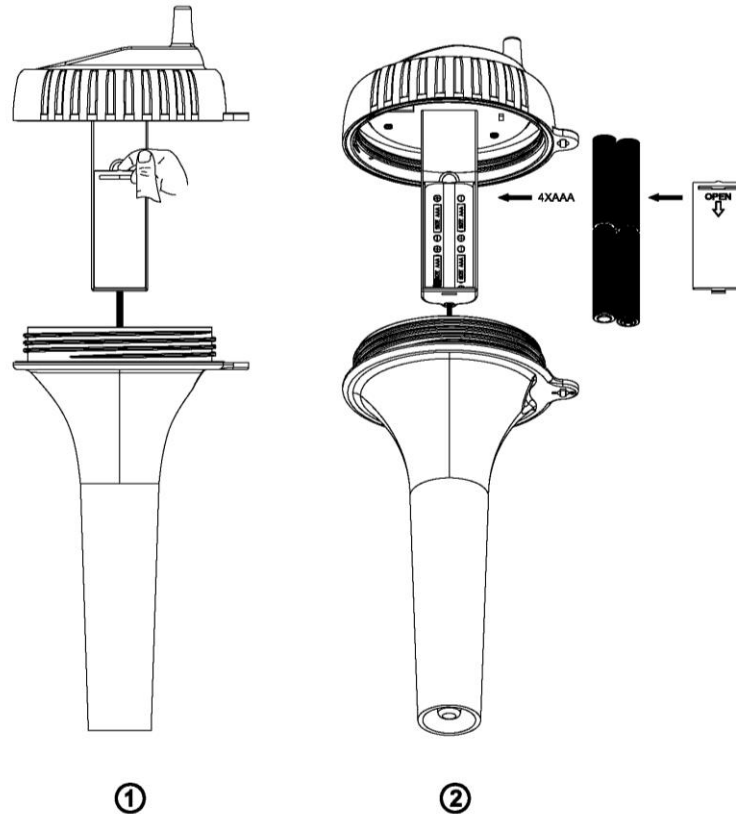

Figure 6

- (1) Open the battery compartment and (2) insert 4 x AAA batteries into the battery compartment, observing the correct battery polarity.
4. After inserting the batteries, the remote sensor LED indicator will light for 4 seconds, and then flash once per 60 seconds thereafter. Each time it flashes, the sensor is transmitting data.
5. Verify the correct channel number (CH) and temperature units of measure ($^{\circ}\text{F}$ vs. $^{\circ}\text{C}$) are on the display, as shown in Figure 7.

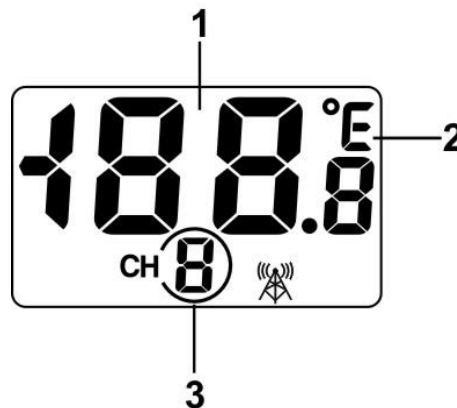

Figure 7

(1) temperature

- (2) temperature units (°F vs. °C)
- (3) channel number

6. Close the battery door. Make sure both red colored gaskets are properly seated in their traces prior to closing the battery door, as shown in Figure 8. Failure to properly seal the floating thermometer will result in water leakage and damage.

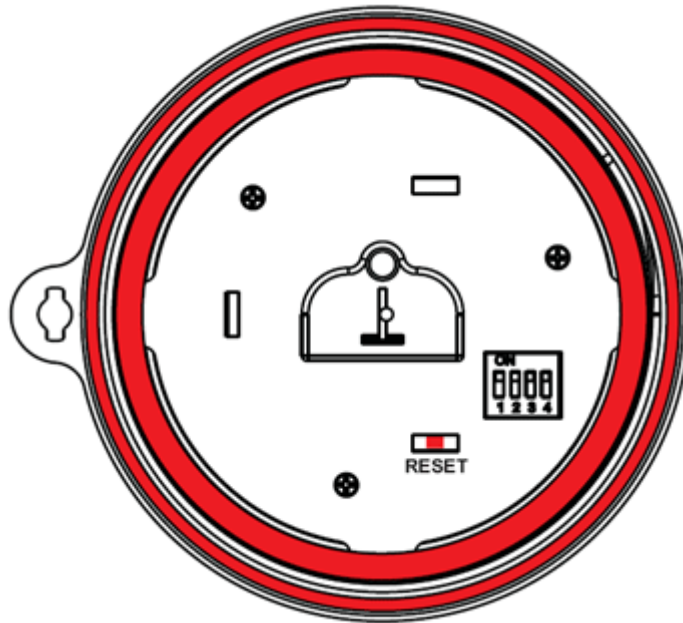

Figure 8

7. To close the lid, (1) Twist the lid until it is firmly locked and the key is aligned. (2) Insert the key and turn 90 degrees to lock the lid, as shown in Figure 9.

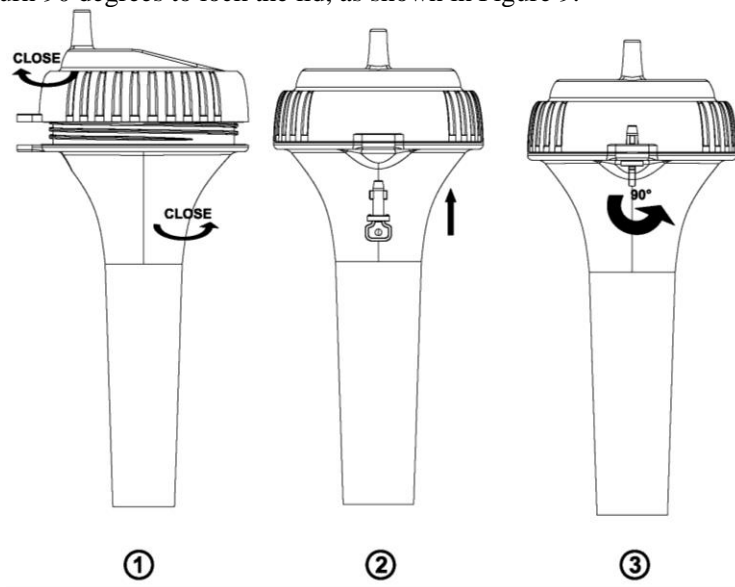

Figure 9

A tether can be added into the key as shown in Figure 10.

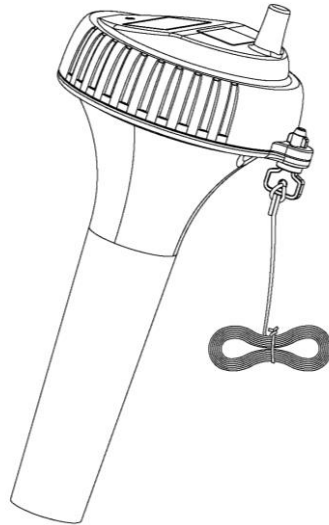

Figure 10

Place the sensor in the water and make sure that it is within the effective transmission range from the display console.

2.3 Sensor Placement

1. Place the sensor in the pool or spa within 100 feet of the display console (Figure 11, reference A). Avoid transmitting through solid earth or ground (Figure 11, reference B). Use a tether (string) to fix the sensor in the pool or spa.
2. Place the console at least three feet away from computers, TVs and wireless phones.
3. Avoid transmitting through solid metal barriers.

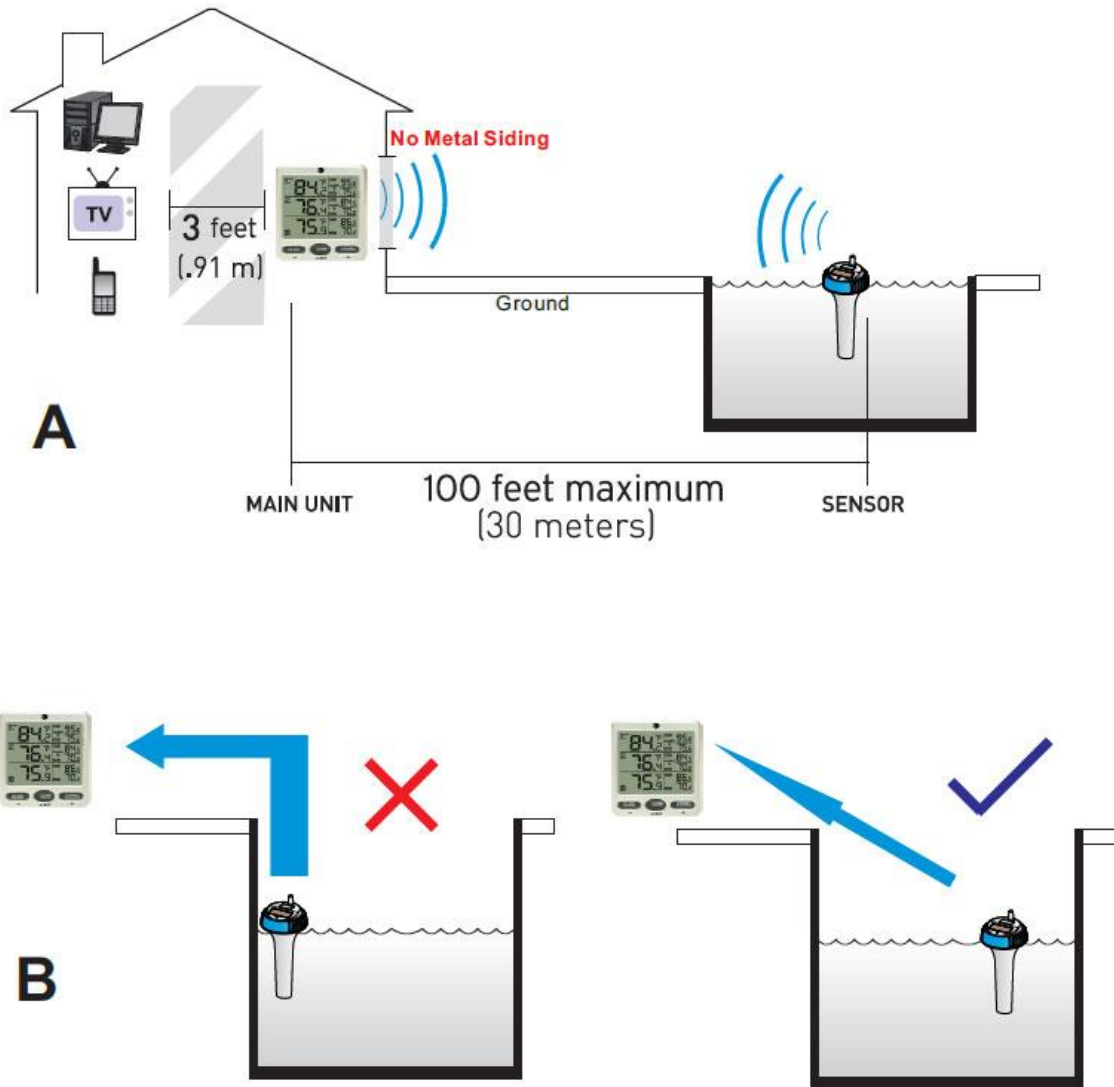

Figure 11

NOTE: The F007PF is designed to float. If the F007PF is used under a cover and the sensor is constantly submerged, the additional pressure will lead to premature gasket failure. Moisture will enter the sensor compartment and cause sensor failure.

3 Maintenance

During each battery change (1-2 years), we recommend applying waterproof silicon grease to the seals:

http://en.wikipedia.org/wiki/Silicone_grease

Silicone grease is available at most hardware and pool stores.

4 Display Console Set Up

Move the remote thermometer(s) about 5 to 10' away from the display console (if the sensor is too close, it may not be received by the display console).

If you have more than one thermometer, make sure they are all powered up and transmitting on different channels. Remove the battery door on the back of the display, as shown in Figure 12.

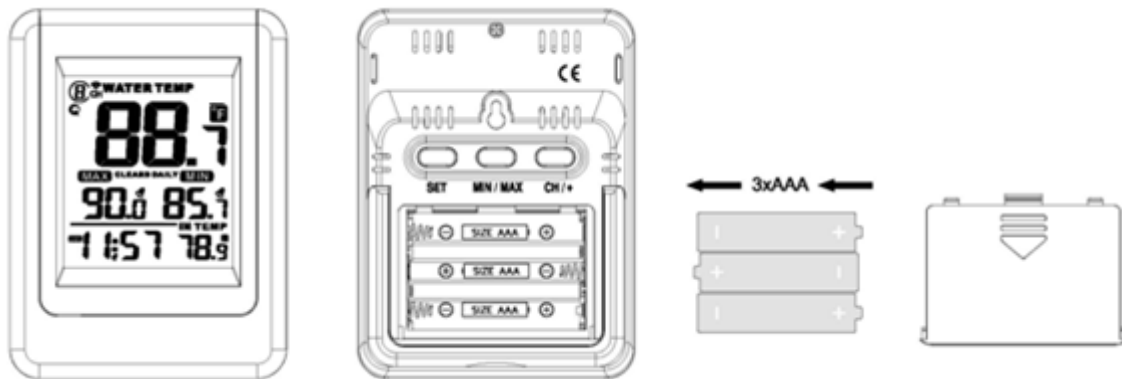



Figure 12

Fold out the desk stand, remove the battery cover, and insert three AAA (alkaline or lithium, avoid rechargeable) batteries in the back of the display console. All of the LCD segments will light up for a few seconds (to verify all segments are operating properly).

1. Replace the battery door, and place the console in the upright position with the desk stand folded out.

The console will instantly display time, indoor temperature as designated by the **IN TEMP** icon. The remote temperature will update on the display within a few minutes on the appropriate channel.

While in the search mode, the remote search icon  will be constantly displayed.

If you have more than once remote sensor (up to eight remotes are supported), the display will automatically toggle between sensors until all sensors have reported in.

Do not touch any buttons until the remote sensor has reported in, or the radio search icon  is no longer on, otherwise the remote sensor search mode will be terminated. When the remote sensor temperature has been received, the console will automatically switch to the normal mode, and all further settings can be performed.

If the remote does not update, please reference the troubleshooting guide in Section 8.

4.1 Display Console Layout

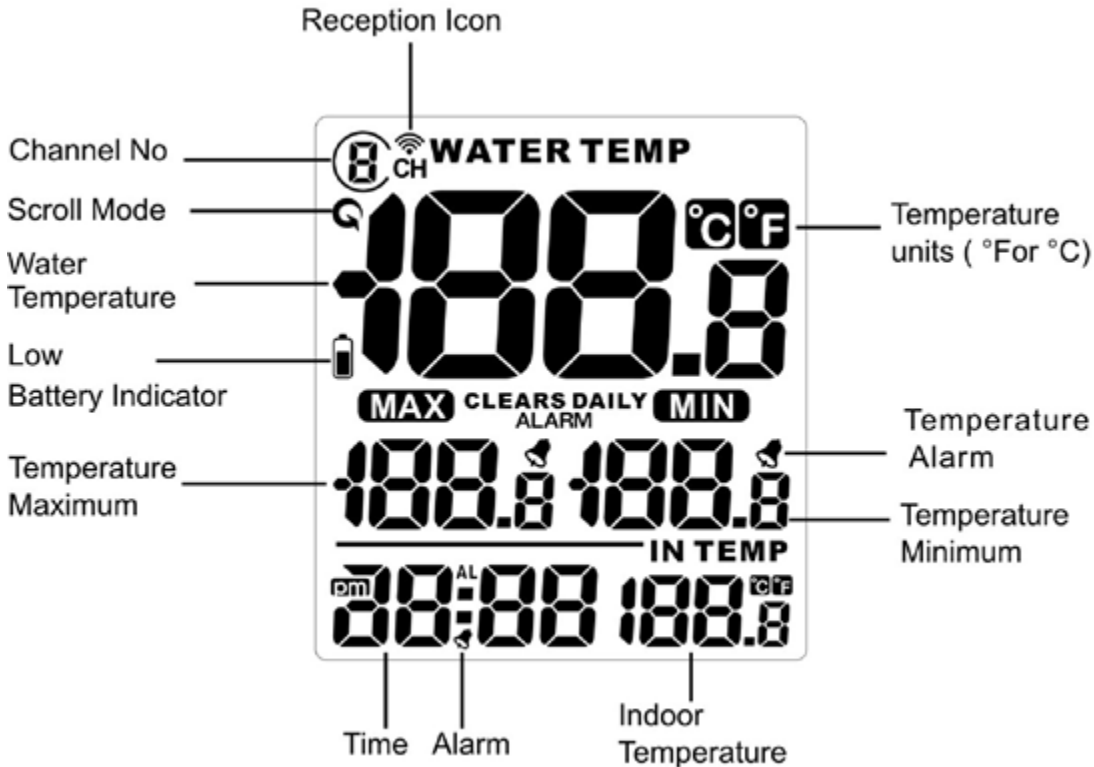



Figure 13

4.2 Sensor Operation Verification

Verify the indoor and outdoor temperature match closely with the console and sensor array in the same location (about 5 to 10' apart). The sensors should be within 2°F (the accuracy is $\pm 1^\circ\text{F}$). Allow about 30 minutes for both sensors to stabilize. The temperature can be adjusted or calibrated later to match each other or a known source.

5 Display Features

5.1 Console Operation



 **Note:** The console has three buttons for easy operation: **SET** button, **MIN/MAX** button, and **CH/+** button.

5.1.1 Set Mode

The Set Mode allows you to set the time and time format, time alarm and units of measure.

To enter the set mode, press and hold the **SET** key for 3 seconds.

1. **12 hr/24 hr time format.** Press the [+] key to switch between 12 and 24 hour format. Press the SET key to advance to the next setting.
2. **Hour.** Press the [+] or [-] key to increase or decrease the hour. Press the SET key to

- advance to the next setting.
3. **Minute.** Press the [+] or [-] key to increase or decrease the minute. Press the **SET** key to advance to the next setting.
 4. **Alarm Hour.** Press the [+] or [-] key to increase or decrease the alarm hour. While the alarm value is flashing, press and hold the **SET** button for three seconds to toggle the alarm on and off the alarm. The time alarm icon will appear  when set, and disappear when disabled. Press (do not hold) the **SET** key to advance to the next setting.
 5. **Alarm Minute.** Press the [+] or [-] key to increase or decrease the alarm minute. While the alarm value is flashing, press and hold the **SET** button for three seconds to toggle the alarm on and off the alarm. The time alarm icon will appear  when set, and disappear when disabled. Press (do not hold) the **SET** key to advance to the next setting.
 6. **Temperature Units of Measure.** Press the [+] key to switch between °F and °C units of measure. Press the **SET** key to advance to the next setting.
 7. **Max/Min Clearing.** The Max/Min can be programmed to clear daily (at midnight) or manually. Press the [+] key to switch between “Clears Daily” and Clears Manually. Press the **SET** key to exit setting.

5.1.2 Viewing the High and Low Alarms

The high and low alarms can be set for Channels 1 and 2 only. Press the **CH/+** button to switch the display between Channel 1 and 2.

Next, press the **SET** button to view the High (**MAX**) and LOW (**MIN**) alarm along with the alarm time. Press the **SET** button again to return to the normal mode.

5.1.3 Alarm Defaults

Channel	Default Condition	HI ALARM (temperature) °F	LOW ALARM (temperature)°F
1	OFF	100	60
2	OFF	110	90

5.1.4 Setting the Min and Max Alarm

The high and low alarms can be set for Channels 1 and 2 only. Press the **CH/+** button to switch the display between Channel 1 and 2.

Next, press the **SET** button once, and the alarm icon will appear **ALARM** ,Press and hold the **SET** button for 3 seconds, and the temperature **HIGH (max)** alarm will flash. Press the **CH/+** button to increase the **HIGH** alarm and the **MIN/MAX** button to decrease the **HIGH** alarm. Press and hold the + or - button to change rapidly. While the alarm value is flashing, press and hold the **SET** button for three seconds to toggle the alarm on and off the alarm. The alarm icon will appear  when set, and disappear when disabled.

Press (do not hold) the **SET** button again to set the **LOW (min)** temperature alarm. The **LOW** alarm for temperature will flash. Press the **CH/+** button to increase the **LOW** alarm and the **MIN/MAX** button to decrease the **LOW** alarm. Press and hold the + or - button to change rapidly. While the alarm value is flashing, press and hold the **SET** button for three seconds to toggle the alarm on and off the alarm. The alarm icon will appear  when set, and disappear when disabled.

5.2 Manually Reset Max/Min

In normal mode, Press the **MIN/MAX** button once to view the MAX values. Press the **MIN/MAX** button again to view the MIN values.

Press the **MIN/MAX** button again to return to normal mode.





To reset the Max/Min values, press and hold the **MIN/MAX-** button for 3 seconds.

5.3 Channel Selection

Press the **CH/+** button to switch the display between remote sensors 1 through 8, and scroll mode . In scroll mode, all of detected outdoor sensors will be displayed in five second intervals.

5.4 Sensor Search Mode

If any of the sensor communication is lost, dashes (---) will be displayed on the screen. To reacquire the signal:

1. If a specific channel is lost, press the **CH/+** button to display this channel, then Press and hold the **CH/+** button for **3** seconds, and the remote search icon  will be constantly displayed for up to 3 minutes. Once the signal is reacquired, the remote search icon  will turn off, and the current values will be displayed.
2. If new sensors are added, subtracted, or multiple sensor channels are lost, Press and hold the **CH/+** button for **5** seconds (on any channel), and the remote search icon  will be constantly displayed for up to 10 minutes. Once the signal is reacquired, the remote search icon  will turn off, and the current values will be displayed.

5.5 Best Practices for Wireless Communication

Wireless communication is susceptible to interference, distance, walls and metal barriers. We recommend the following best practices for trouble free wireless communication.

1. **Electro-Magnetic Interference (EMI).** Keep the console several feet away from computer monitors and TVs.
2. **Radio Frequency Interference (RFI).** If you have other 433 MHz devices and communication is intermittent, try turning off these other devices for troubleshooting purposes. You may need to relocate the transmitters or receivers to avoid intermittent communication.
3. **Line of Sight Rating.** This device is rated at 150 feet line of sight (no interference, barriers or walls) but typically you will get 100 feet maximum under most real-world installations, which include passing through barriers or walls.
4. **Metal Barriers.** Radio frequency will not pass through metal barriers such as aluminum siding. If you have metal siding, align the remote and console through a window to get a clear line of sight.

5.6 Adjustment or Calibration

 **Note:** The calibrated value can only be adjusted on the console. The remote sensor(s) always displays the un-calibrated or measured value.

The purpose of calibration is to fine tune or correct for any sensor error associated with the devices margin of error. The measurement can be adjusted from the console to calibrate to a known source.

Calibration is only useful if you have a known calibrated source you can compare it against, and is

optional. This section discusses practices, procedures and sources for sensor calibration to reduce manufacturing and degradation errors. Do not compare your readings obtained from sources such as the internet, radio, television or newspapers. They are in a different location and typically update once per hour.

The purpose of your weather station is to measure conditions of your surroundings, which vary significantly from location to location.

5.6.1 Remote Sensor Temperature Calibration

Prior to entering the calibration mode, press the **CH/+** button to select the remote temperature sensor you wish to adjust.

To enter the temperature calibration mode, press and hold the **SET and CH/+** buttons at the same time for 5 seconds and the remote temperature value will begin flashing. Press the **CH/+** button to increase the temperature and the **MIN/MAX** button to decrease the temperature reading in 0.1° increments. To rapidly increase (or decrease) the temperature reading, press and hold the **CH/+** or **MIN/MAX** button.

To return the temperature to the actual or uncalibrated measurement, press the **SET** button.

Once the displayed temperature equals the calibrated source, press and hold the **SET** button for three seconds, or wait 15 seconds for timeout, and the temperature value will stop flashing.

5.6.2 Indoor Temperature Calibration

To enter the indoor temperature calibration mode, press and hold the **SET and MIN/MAX** buttons at the same time for 5 seconds and the IN-TEMP temperature value will begin flashing. Press the **CH/+** button to increase the temperature and the **MIN/MAX** button to decrease the temperature reading in 0.1° increments. To rapidly increase (or decrease) the temperature reading, press and hold the **CH/+** or **MIN/MAX** button.

To return the temperature to the actual or uncalibrated measurement, press the **SET** button.

Once the displayed temperature equals the calibrated source, press and hold the **SET** button for three seconds, or wait 15 seconds for timeout, and the temperature value will stop flashing.

 **Discussion:** Temperature errors can occur when a sensor is placed too close to a heat source (such as a building structure, the ground or trees).

To calibrate temperature, we recommend a mercury or red spirit (fluid) thermometer. Bi-metal (dial) and other digital thermometers are not a good source and have their own margin of error. Using a local weather station in your area is also a poor source due to changes in location, timing (airport weather stations are only updated once per hour) and possible calibration errors (many official weather stations are not properly installed and calibrated).

Place the sensor in a shaded, controlled environment next to the fluid thermometer, and allow the sensor to stabilize for 48 hours. Compare this temperature to the fluid thermometer and adjust the console to match the fluid thermometer.

6 Glossary of Terms

Term	Definition
Accuracy	Accuracy is defined as the ability of a measurement to match the actual value of the quantity being measured.
Hygrometer	A hygrometer is a device that measures relative humidity. Relative humidity is a term used to describe the amount or percentage of water vapor that exists in air.
Range	Range is defined as the amount or extent a value can be measured.

7 Specifications

7.1 Wireless Specifications

- Line of sight wireless transmission (in open air): 150 feet, 100 feet under most conditions.
- Frequency: 433 MHz
- Update Rate: 60 seconds

7.2 Measurement Specifications

The following table provides specifications for the measured parameters.

Measurement	Range	Accuracy	Resolution
Indoor Temperature	32 to 140 °F	± 1 °F	0.1 °F
Pool Float Temperature	-40 to 140 °F	± 1 °F	0.1 °F



7.3 Power Consumption

- Base station (display console) : 3 x AAA 1.5V Alkaline or Lithium batteries (not included)
- Remote sensor : 4 x AAA 1.5V Alkaline or Lithium batteries (not included)
- Battery life: Minimum 12 months for base station with one sensor and excellent reception. Intermittent reception and multiple sensors may reduce the battery life. Minimum 24 months for water sensor (use lithium batteries in cold weather climates less than -4 °F)

8 Troubleshooting Guide

If your question is not answered here, you can contact us as follows:

1. Email Support: support@ambientweather.com
2. Technical Support: 480-346-3398 (M-F 8am to 3pm Arizona Time)

Problem	Solution
Wireless remote (thermo-hygrometer) not reporting in to console. There are dashes (---) on the display console.	If any of the sensor communication is lost, dashes (---) will be displayed on the screen. To reacquire the signal, press and hold the CHANNEL/+ button for 3 seconds, and the remote search icon  will be constantly displayed. Once the signal is reacquired, the remote search icon  will turn off, and the current values will be displayed.

Problem	Solution
	<p>The maximum line of sight communication range is 300' and 100' under most conditions. Move the sensor assembly closer to the display console.</p> <p>If the sensor assembly is too close (less than 5'), move the sensor assembly away from the display console.</p> <p>Make sure the remote sensor LCD display is working and the transmitter light is flashing once per 60 seconds.</p> <p>Install a fresh set of batteries in the remote thermo-hygrometer. For cold weather environments, install lithium batteries.</p> <p>Make sure the remote sensors are not transmitting through solid metal (acts as an RF shield), or earth barrier (down a hill).</p> <p>Move the display console around electrical noise generating devices, such as computers, TVs and other wireless transmitters or receivers.</p> <p>Move the remote sensor to a higher location. Move the remote sensor to a closer location.</p>
Pool float does not power up.	<p>If the display does not power up after inserting the batteries, press the reset button shown in Figure 4.</p> <p>If your pool float does not include a reset button, cover the solar panel with one hand, remove the batteries, wait 60 seconds, reinsert the batteries, and uncover the solar panel.</p>
Temperature sensor reads too high in the day time.	<p>Make sure the thermo-hygrometer is mounted in a shaded area on the north facing wall. Consider the following radiation shield if this is not possible: http://www.ambientweather.com/amwespatean.html</p>
Indoor and Outdoor Temperature do not agree	<p>Allow up to one hour for the sensors to stabilize due to signal filtering. The indoor and outdoor temperature sensors should agree within 2 °F (the sensor accuracy is ± 1 °F).</p> <p>Use the calibration feature to match the indoor and outdoor temperature to a known source.</p>
Display console contrast is weak	Replace console batteries with a fresh set of batteries.

9 Accessories

The following software and hardware accessories are available for this weather station at www.AmbientWeather.com.

Accessory	Description
Ambient Weather F007PF Wireless Water Thermometer for WS-14 Weather Stations	Add additional remote thermometers. Supports up to eight remote sensors.
Ambient Weather WS-14-C WS-14 Big Digit 8-Channel Wireless Thermo-Hygrometer Console Only	Add as many display consoles as you like to your existing system to display the remote sensor in different locations.
Energizer AAAS Lithium Battery (2-pack) - Batteries for Long Life and Cold Climates	AAA lithium batteries for cold weather climates.
Ambient Weather SRS100LX Temperature and Humidity Solar Radiation Shield	Solar Radiation Shield improves temperature accuracy for hot weather climates. Remove the rain guard and install over thermo-hygrometer.
Ambient Weather Humidity Calibration Kits	One step calibration kits for digital hygrometers use salt slurry formula to accurately calibrate the indoor and outdoor hygrometers.

10 Liability Disclaimer

Please help in the preservation of the environment and return used batteries to an authorized depot. The electrical and electronic wastes contain hazardous substances. Disposal of electronic waste in wild country and/or in unauthorized grounds strongly damages the environment.

Reading the “User manual” is highly recommended. The manufacturer and supplier cannot accept any responsibility for any incorrect readings and any consequences that occur should an inaccurate reading take place.

This product is designed for use in the home only as indication of weather conditions. This product is not to be used for medical purposes or for public information.

The specifications of this product may change without prior notice.

This product is not a toy. Keep out of the reach of children.

No part of this manual may be reproduced without written authorization of the manufacturer.

Ambient, LLC WILL NOT ASSUME LIABILITY FOR INCIDENTAL, CONSEQUENTIAL, PUNITIVE, OR OTHER SIMILAR DAMAGES ASSOCIATED WITH THE OPERATION OR MALFUNCTION OF THIS PRODUCT.

11 FCC Statement

Statement according to FCC part 15.19:

This device complies with part 15 of the FCC rules. Operation is subject to the following two conditions:

1. This device may not cause harmful interference.
2. This device must accept any interference received, including interference that may cause undesired operation.

Statement according to FCC part 15.21:

Modifications not expressly approved by this company could void the user's authority to operate the equipment.

Statement according to FCC part 15.105:

NOTE: This equipment has been tested and found to comply with the limits for a Class B digital device, pursuant to Part 15 of the FCC Rules. These limits are designed to provide reasonable protection against harmful interference in a residential installation. This equipment generates, uses and can radiate radio frequency energy and, if not installed and used in accordance with the instructions, may cause harmful interference to radio communications.

However, there is no guarantee that interference will not occur in a particular installation. If this equipment does cause harmful interference to radio or television reception, which can be determined by turning the equipment off and on, the user is encouraged to try to correct the interference by one or more of the following measures:

- Reorient or relocate the receiving antenna.
- Increase the separation between the equipment and receiver.
- Connect the equipment into an outlet on a circuit different from that to which the receiver is connected.
- Consult the dealer or an experienced radio/TV technician for help.

12 Warranty Information

Ambient, LLC provides a 1-year limited warranty on this product against manufacturing defects in materials and workmanship.

This limited warranty begins on the original date of purchase, is valid only on products purchased and only to the original purchaser of this product. To receive warranty service, the purchaser must contact Ambient, LLC for problem determination and service procedures.

Warranty service can only be performed by a Ambient, LLC. The original dated bill of sale must be presented upon request as proof of purchase to Ambient, LLC.

Your Ambient, LLC warranty covers all defects in material and workmanship with the following specified exceptions: (1) damage caused by accident, unreasonable use or neglect (lack of reasonable and necessary maintenance); (2) damage resulting from failure to follow instructions contained in your owner's manual; (3) damage resulting from the performance of repairs or alterations by someone other than an authorized Ambient, LLC authorized service center; (4) units used for other than home use (5) applications and uses that this product was not intended (6) the products inability to receive a signal due to any source of interference or metal obstructions and (7) extreme acts of nature, such as lightning strikes or floods.

This warranty covers only actual defects within the product itself, and does not cover the cost of installation or removal from a fixed installation, normal set-up or adjustments, claims based on misrepresentation by the seller or performance variations resulting from installation-related circumstances.

